

## CVS Design EZ Control Valve

### Introduction

This instruction manual includes installation, maintenance, and parts information for 1 through 2-inch Design EZ valves through Class 600 ratings.

For instructions covering the actuator and accessories, refer to separate manuals.

Only qualified personnel through training or experience should install, operate, and maintain a Design EZ valve. If you have any questions about these instructions, contact your CVS Controls representative before proceeding.

### Applications and Features

**Excellent Pressure and Flow Control:**  
CVS Controls Design EZ valves are globe-style with integral end connections, post guiding, and quick-change trim. Typical applications include chemical or hydrocarbon processing, as well as applications that require control of viscous, non-lubricating or other hard-to-handle fluids.

**End Connection Styles** are flanged Class 150, 300, and 600 raised face, ring type joint or flat face as per ASME B16.5 or screwed/socket welding consistent with ASME B16.1.

**Maximum Inlet Pressures<sup>1</sup>** for flanged connections are consistent with Class 150, 300, or 600 as per ASME B16.34. Screwed connections are consistent with Class 600 as per ASME B16.34-latest edition.

#### Material Temperature Capabilities:

Optional: NACE MRO175/ISO15156-2009  
Standard 316 SS Packing Box Parts



*Figure 1. Design EZ Valve with Type 667 Actuator and 4150 Controller.*

#### Sour Service Capability

Shutoff Classifications per FCI 70-2 and IEC 60534-4; **Metal Seats:** Class IV is standard, Class V is optional. **PTFE Composition Seats:** Class VI.

The CVS Controls Design EZ Flow Characteristics are equal percentage, quick opening, and linear with flow direction up through the seat ring.

## Approximate Weights:

**1-Inch Valve:** 11 kg (25 pounds)

**1-1/2 Inch Valve:** 18 kg (40 pounds)

**2-Inch Valve:** 36 kg (80 pounds)

1. The pressure/temperature limits in this manual and any applicable standard or code limitation for valve should not be exceeded.

---

## Installation

---

***Sudden release of pressure may result personal injury or equipment damage if the valve assembly is installed where service conditions could exceed the limits on the nameplates. Provide a relief valve for overpressure protection as required by government or accepted industry codes and good engineering practices to avoid such injury or damage.***

***Upon ordering, the valve configuration and construction materials were selected to meet particular pressure, temperature, pressure drop, and controlled fluid conditions.***

---

1. Prior to installation of the valve, inspect it and any associated equipment for damage and any foreign material. Ensure the valve interior is clean, that pipelines are free of foreign material, and that the valve is oriented so that pipeline flow is in the same direction as the arrow on the side of the valve.
2. Typical installation of the Design EZ control valve is with the actuator vertical above the valve; however it may be installed in any orientation unless limited by seismic criteria. Other positions may result in uneven valve plug and seat ring retainer wear, and improper operation. With some applications, the actuator may also need to be supported when not in a vertical position. For more information, contact your CVS Controls representative.
3. Use accepted piping and welding practices when installing the valve in the line. During the welding procedure internal elastomeric parts may stay in place. For flanged valves, use a suitable gasket between the valve body flange and pipeline flanges.

## Note:

---

**Post weld heat treating may be required depending on valve body materials used. It is recommended that all trim components be removed if post weld heat treating is to be performed to prevent damage to internal elastomeric and plastic parts, as well as internal metal parts. Shrink-fit pieces and threaded connections may also loosen. Contact your CVS representative for more information.**

---

4. With a leak-off bonnet construction, remove the pipe plugs (key 14) to hook up the leak-off piping. Install a three-valve bypass around the control valve assembly if continuous operation is required during inspection or maintenance.
5. Refer to the actuator mounting procedure in the appropriate instruction manual if the actuator and valve are shipped separately.

---

***Personal injury could result from packing leakage. Valve packing was tightened prior to shipment; however, the packing might require some readjustment to meet specific service conditions.***

---

## Maintenance

Design EZ valve components are subject to normal wear and must be inspected and replaced on a regular scheduled basis. Severe service conditions may require shorter inspection and maintenance intervals. This section includes instructions for packing lubrication, packing maintenance, and trim maintenance.

**Prior to performing any maintenance operations:**

1. **Disconnect any operating lines providing air pressure, electric power, or a control signal to the actuator. Ensure the actuator cannot suddenly open or close the valve.**
2. **Use bypass valves or completely shut off the process to isolate the valve from process pressure. Relieve process pressure from both sides of the valve. Drain the process media from both sides of the valve.**
3. **Vent the pneumatic actuator loading pressure and relieve any actuator spring pre-compression.**
4. **Use lock-out procedures to be sure that the above measures stay in effect.**

**The valve packing box may contain process fluids that are pressurized, even when the valve has been removed from the pipeline. Process fluids may spray out under pressure when removing the packing hardware or packing rings, or when loosening the packing box pipe plug.**

**Should a gasket seal be disturbed by removing or shifting gasketed parts, install a new gasket upon reassembly.**

## Packing Lubrication

An optional lubricator or lubricator/isolating valve (figure 2) is available for PTFE/composition or other packings that require lubrication. It will be installed in an optional tapped hole in the bonnet. Use a good quality silicon-based lubricant. Packing used in oxygen service or in processes with temperatures over 260°C (500°F) do not require lubrication. To operate the lubricator, turn the cap screw clockwise to force the lubricant into the packing box. The lubricator/isolating valve must first be opened and then closed after lubrication is completed.

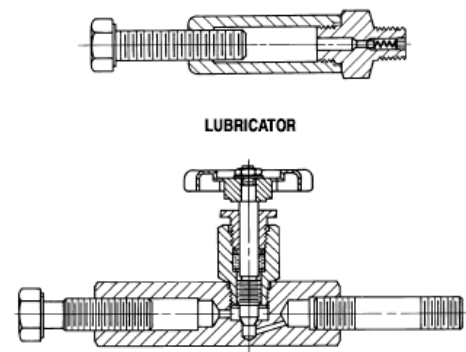

Figure 2: Optional Packing Lubricator, and Lubricator Isolating Valve

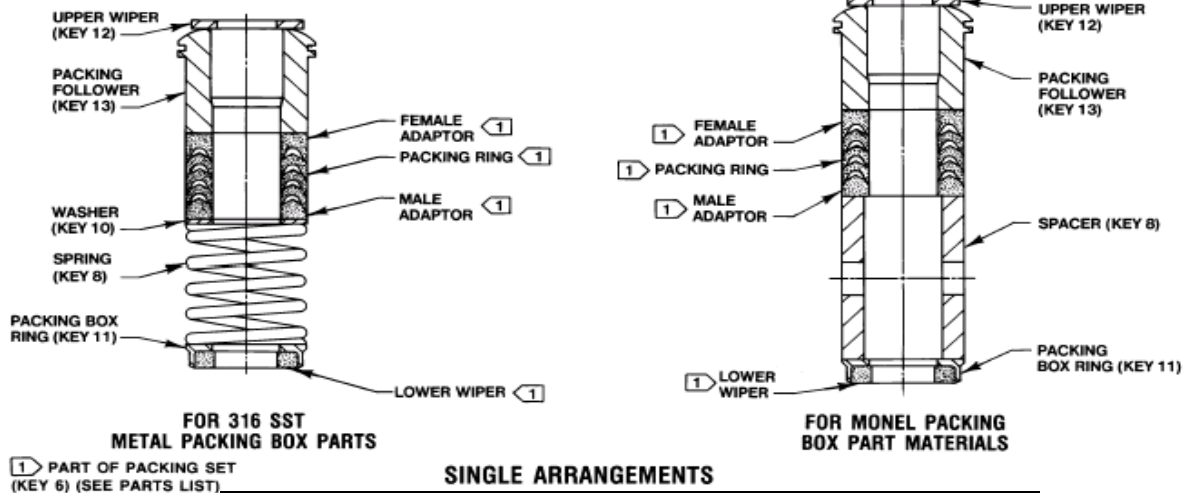

Figure 3: PTFE V-Ring Packing Arrangements for Plain and Extension Bonnets

## Packing Maintenance

---

This section covers PTFE V-ring packing as used in plain and extension bonnets. Unless otherwise indicated, key numbers refer to figure 3 for PTFE V-ring packing.

For spring-loaded single PTFE V-ring packing, the spring (key 8, figure 3) maintains a sealing force on the packing. If leakage is noted around the packing follower (key 13, figure 3), check to be sure the shoulder on the packing follower is touching the bonnet. If the shoulder is not touching the bonnet, tighten the packing flange nuts (key 5, figure 11), until the shoulder is against the bonnet. If leakage cannot be stopped in this manner, proceed to the replacing packing procedure.

If there is unacceptable packing leakage with other than spring-loaded packing, first try to limit the leakage and establish a stem seal by tightening the packing flange nuts.

If the packing is relatively new and tight on the stem, and if tightening the packing flange nuts does not stop the leakage, the valve stem may be worn or nicked so that a seal cannot be made. The surface finish of a valve stem is critical for making a good packing seal. If the leakage comes from the outside diameter of the packing, the leakage may be caused by nicks or scratches around the packing box wall. If performing any of the following procedures, inspect the valve stem and packing box wall for nicks and scratches.

---

## Replacing Packing

---

The following section covers packing replacement as used in plain and extension bonnets. Refer to figure 3 for PTFE V-ring packing.

1. Isolate the control valve from the line pressure and release pressure from both sides of the valve body.  
Drain the process media from both sides of the valve. If using a power actuator, also shut off all pressure lines to the power actuator, and release all pressure from the actuator. Use lock-out procedures to be sure that the above measures stay in effect while you work on the equipment. Observe the warning at the start of the *Maintenance* section.

2. Disconnect the operating lines from the actuator and any leak-off piping from the bonnet. Disconnect the stem connector and then remove the actuator from the valve by unscrewing the yoke locknut (key 15, figure 11).

---

***Loosen the bonnet by following the instructions in the next step to avoid personal injury or property damage. Do not remove a stuck bonnet by pulling on it with equipment that can stretch or store energy in any other manner. The sudden release of stored energy can cause uncontrolled movement of the bonnet.***

***The following step also provides additional assurance that the valve body fluid pressure has been relieved.***

---

3. Hex nuts (key 16, figure 12) attach the bonnet to the valve. Loosen these nuts or cap screws approximately 3 mm (1/8 inch). Then loosen the body-to-bonnet gasketed joint by either rocking the bonnet or prying between the bonnet and valve body. Work the prying tool around the bonnet until the bonnet loosens.

4. Loosen the packing flange nuts (key 5, figure 11) so that the packing is not tight on the valve stem. Remove any travel indicator parts and stem locknuts from the valve stem threads.

---

***When lifting the bonnet, temporarily install a valve stem locknut on the valve stem. Avoid damaging the seating surface caused by the valve plug and stem assembly dropping from the bonnet after being lifted part way out.***

***This locknut will prevent the valve plug and stem assembly from dropping out of the bonnet.***

---

5. Completely remove the cap screws (not shown) or hex nuts (key 16, figure 12) that bolt the bonnet and valve body together and carefully lift the bonnet off.
6. Remove the locknut and separate the valve plug and stem from the bonnet. Set the parts on a protective surface to prevent damage to gasket or seating surfaces.

## **Replacing Packing Continued,**

7. Remove the bonnet gasket (key 10, figure 12) and cover the opening in the valve to protect the gasket surface and to prevent foreign material from getting into the valve body cavity.

8. Remove the packing flange nuts, packing flange, upper wiper, and packing follower (keys 5, 3, 12, and 13, figure 11). Carefully push out all the remaining packing parts from the valve side of the bonnet using a rounded rod or other tool that will not scratch the packing box wall. Clean the packing box and the metal packing parts.

9. Inspect the valve stem threads and the packing box surfaces for any sharp edges which might cut the packing. Scratches or burrs could cause packing box leakage or damage to the new packing. If the surface condition cannot be improved by light sanding, replace the damaged parts.

10. Remove the covering protecting the valve cavity and install a new bonnet gasket (key 10, figure 12), making sure the gasket seating surfaces are clean and smooth. Then slide the bonnet over the stem and onto the stud bolts (key 15, figure 12), or onto the valve cavity if cap screws (not shown) are used instead.

---

***Using proper tightening procedures in step 11 compresses the spiral wound gasket (key 12, figure 13) enough to both load and seal the seat ring gasket (key 13, figure 12). The tightening procedures also compresses the outer edge of the bonnet gasket (key 10, figure 12) enough to seal the body-to-bonnet joint.***

***Use accepted bolting practices thread the nuts onto the studs, and in a crisscross pattern tighten the nuts. Because of the boltup characteristics of spiral wound gaskets, tightening one cap screw or nut may loosen an adjacent cap screw or nut. Repeat the crisscross-tightening pattern several times until each cap screw or nut is tight and the body-to-bonnet seal is made. When the operating temperature has been reached, perform the torque procedure once again.***

---

11. Install bolting, using accepted bolting procedures. The bolt torques in table 2 may be used as guidelines unless accepted bolting procedures dictate otherwise.

12. Install new packing and the metal packing box parts according to the appropriate arrangement in figure 3. Place a smooth-edged pipe over the valve stem and gently tap each soft packing part into the packing box, being sure that air is not trapped between adjacent soft parts.

13. Slide the packing follower, upper wiper, and packing flange (keys 13, 12, and 3, figure 11) into position. Lubricate the packing flange studs (key 4, figure 11) and the faces of the packing flange nuts (key 5, figure 11). Install the packing flange nuts.

---

***The torque values discussed in step 14 and shown in table 3 are recommended guidelines only and are presented as a starting point for this procedure. Tightening the packing flange nuts to a torque value that exceeds the table guidelines, in order to obtain a seal, may indicate other problems.***

---

14. **For spring-loaded PTFE V-ring packing,** tighten the packing flange nuts until the shoulder on the packing follower (key 13, figure 11) contacts the bonnet.

**For other packing types,** tighten the packing flange nuts alternately in small equal increments until one of the nuts reaches the minimum recommended torque shown in table 3. Then, tighten the remaining flange nuts until the packing flange is level and at a 90-degree angle to the valve stem.

15. Mount the actuator on the valve body and reconnect the actuator and valve stem according to the procedure in the appropriate actuator instruction manual.

---

## Trim Maintenance

---

The following procedures describe how the valve trim can be completely disassembled. When inspection or repairs are required, perform only those steps necessary to accomplish the task. Refer to the warning at the start of the *Maintenance* section.

---

## Disassembly

---

Key numbers referenced in the following steps are found in figure 12, unless otherwise indicated.

1. Remove the actuator and the bonnet according to steps 1 through 6 of the *Replacing Packing* Procedure of the *Maintenance* section.

### NOTE:

---

**To avoid personal injury due to leaking fluids, avoid damaging gasket sealing surfaces.**

**The surface finish of the valve stem (key 7) is critical for making a good packing seal. The inside surface of the seat ring retainer is critical for smooth operation of the valve plug.**

**The seating surfaces of the valve plug and seat ring (keys 2 and 9) are critical for proper shutoff.**

**Unless inspection reveals otherwise, assume all these parts are in good condition and protect them accordingly. Gasket selection criteria is provided on page 31 of this instruction manual.**

---

2. Packing parts can be removed if desired. Replace these parts as described in the *Replacing Packing* procedure.

### Valves with Plain or Extension Bonnets

Perform the following steps to remove the valve trim.

1. Lift the valve plug and stem assembly or the plug guide, disk retainer, and disk (keys 27, 28, and 29, figure 13) if used, out of the valve body and set it on a protective surface.

---

**With some valve plug sizes and configurations, the seat ring retainer and bushing assembly (keys 3 and 26, figures 12 and 13) will come out of the valve body with the valve plug and stem assembly, and in other valve plug sizes and configurations, the valve plug or tip will slide through the seat ring retainer and bushing assembly, leaving the retainer and bushing assembly in the valve body.**

---

2. With the valve plug and stem assembly out of the valve, either slide the seat ring retainer and bushing assembly (keys 3 and 26), and gaskets and shim (keys 10, 12, and 25) up over the valve plug and stem or lift the seat ring retainer and bushing assembly and associated gaskets and shim out of the valve body. If the valve plug is to be reused, protect the valve plug seating surface to prevent scratches.

3. **For valves with metal seats**, drive out the pin (key 8) and unscrew the valve stem (key 7) from the valve plug (key 2).

4. **For valves with 1/4 and 3/8-inch ports and composition seats**, refer to figure 13. Drive out the pin (key 8) and unscrew the valve stem (key 7) from the valve plug guide (key 27). Unscrew the disk retainer (key 28) from the valve plug guide. Remove the disk (key 29) from the valve plug tip (key 30).

**For valves with 1/2 through 2-inch ports and composition seats**, refer to figure 13. Drive out the pin (key 8) and unscrew the valve stem (key 7) from the valve plug guide (key 27). Drive out pin (key 31) and unscrew the tip (key 30) from the valve plug guide. Remove the disk (key 29) from the valve plug guide.

## Lapping Metal Seats

With metal-seat constructions, seating surfaces of the valve plug and seat ring (key 2, figure 12) can be lapped for improved shutoff. (Deep nicks should be machined out rather than ground out.) Use a good quality lapping compound of a mixture of 280 to 600-grit. Apply the compound to the bottom of the valve plug.

Assemble the valve to the extent that the seat ring retainer is in place and the bonnet is bolted to the valve body. A simple handle can be made from a piece of strap iron locked to the valve plug stem with nuts. Rotate the handle alternately in each direction to lap the seats. After lapping, remove the bonnet and clean the seat surfaces. Completely assemble as described in the assembly portion of the *Trim Maintenance* procedure and test the valve for shutoff. Repeat the lapping procedure if leakage is still excessive.

## Assembly

The following procedure assumes that all the trim and associated gaskets were removed from the valve body. If these parts were not all removed, start the assembly procedure at the appropriate step. Key numbers referenced in the following steps are found in figure 12, unless otherwise indicated.

VALVE STEM		BOLT TORQUE		DRILL SIZE, INCH	D DIMENSION	
mm	Inch	N•m	Lbf•ft		mm	Inch
9.5	3/8	40-47	25-35	3/32	16	5/8
12.7	1/2	81-115	60-85	1/8	19	3/4
19.0	3/4	237-339	175-250	3/16	25	1

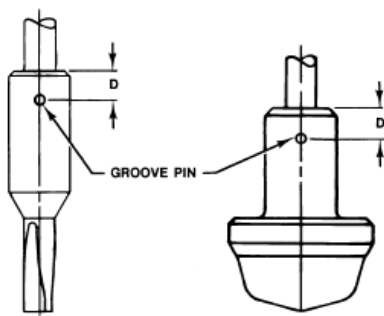

Figure 10. Bolt Torque for Plug/Stem Connection and Plug/Adaptor Connection and Pin Replacement

## Valves with Plain or Extension Bonnets

Perform the following steps to assemble and install the trim.

**To avoid weakening the stem that may cause failure in service, never reuse an old stem with a new valve plug. Using an old stem with a new plug requires drilling a new pin hole in the stem, which will weaken the stem. However, a used valve plug may be reused with a new stem.**

1. **For valves with metal seats**, screw the valve stem (key 7) into the valve plug (key 2). Tighten to the torque valve given in figure 10. Refer to figure 10 to select the proper drill size. Drill through the stem using the hole in the valve plug as a guide. Remove any chips or burrs and drive in a new pin (key 8) to lock the assembly.

2. **For valves with 1/4 and 3/8-inch ports and composition seats**, refer to figure 13. Place the disk (key 29) on the valve plug tip (key 30). Place the disk retainer (key 28) over the disk, and then thread the disk retainer onto the valve plug guide (key 27).

**To avoid failure in service for valves with 1/2 through 1-inch ports and composition seats, never reuse an old valve plug guide with a new valve plug tip. Using an old valve plug guide with a new plug tip requires drilling a new pinhole in the valve plug guide, which will weaken the guide. However, a used valve plug tip may be reused with a new valve plug guide.**

**For valves with 1/2 through 1-inch ports and composition seats**, refer to figure 13. Insert the disk (key 29) in the valve plug guide (key 27). Screw the tip (key 30) onto the valve plug guide to clamp the disk in place. Using a 3/32-inch bit, drill through the valve plug guide using the hole in the tip as a drilling guide. Remove any chips or burrs and drive in a new pin (key 31).

## Assembly Continued,

---

***To avoid failure in service for valves with 1-1/2 and 2-inch ports and composition seats, never reuse an old valve plug tip with a new valve plug guide. Using an old valve plug tip with a new valve plug guide requires drilling a new pinhole in the valve plug tip which will weaken the tip. However, a used valve plug guide may be reused with a new valve plug tip.***

---

**For valves with 1-1/2 and 2-inch ports and composition seats, refer to figure 13.** Insert the disk (key 29) in the valve plug guide (key 27). Screw the tip (key 30) into the valve plug guide to clamp the disk in place. Using a 3/32-inch bit, drill through the valve plug tip using the hole in the valve plug guide as a drilling guide. Remove any chips or burrs and drive in a new pin (key 31).

---

***To avoid failure in service, never reuse an old stem with a new valve plug guide. Using an old stem with a new valve plug guide requires drilling a new pin hole in the stem, which will weaken the stem. However, a used valve plug guide may be reused with a new stem except for valves with ½ through 1-inch ports and composition seats (see to figure 13). For these constructions, a used valve plug guide should only be used if the tip is reused.***

---

3. **For all valves with composition seats,** screw the valve stem (key 7) into the valve plug guide (key 27, figure 13). Tighten to the torque value given in figure 10. Refer to figure 10 to select the proper drill size. Drill through the stem, using the hole in the valve plug guide as a drilling guide. Remove any chips or burrs and drive in a new pin (key 8) to lock the assembly.

4. Install the seat ring gasket (key 13), and replace the seat ring (key 9). With some valve plug sizes and configurations, the valve plug or tip will slide through the seat ring retainer and bushing assembly (keys 3 and 26), and in other configurations it won't.

5. If the valve plug (key 2) or valve plug tip (key 30, figure 13) will not slide through the seat ring retainer and bushing assembly (keys 3 and 26), proceed as follows:

a. Place the seat ring retainer and bushing assembly (keys 3 and 26) over the stem of valve plug and stem assembly or over the stem of the valve plug guide and stem assembly.

b. Install the seat ring retainer and bushing assembly, which also includes the valve plug and stem assembly or valve plug guide and stem assembly, on the top of the seat ring, ensuring that the seat ring retainer slips onto the seat ring properly. Any rotation orientation of the seat ring retainer with respect to the valve body is acceptable.

c. Place the spiral wound gasket, shim, and bonnet gasket (keys 12, 25, and 10) on the shoulder of the seat ring retainer.

6. If the valve plug (key 2) or the valve plug tip (key 30, figure 13) will slide through the seat ring retainer and bushing assembly (keys 3 and 26), proceed as follows:

a. Install the seat ring retainer and bushing assembly on the top of the seat ring, ensuring that the seat ring retainer slips onto the seat ring properly. Any rotation orientation of the seat ring retainer with respect to the valve body is acceptable.

b. Place the spiral wound gasket, shim, and bonnet gasket (keys 12, 25, and 10) on the shoulder of the seat ring retainer.

c. Slide the valve plug and stem assembly or the valve plug guide and stem assembly into the seat ring retainer and bushing assembly (keys 3 and 26).

## Assembly Continued,

7. Mount the bonnet on the valve body and complete the assembly according to steps 10 through 15 of the *Replacing Packing* procedure, omitting steps 12 and 13 if new packing is not being installed, and being sure to observe the note prior to step 11.

**Composition seats, refer to figure 13.** Insert the disk (key 29) in the valve plug guide (key 27). Screw the tip (key 30) into the valve plug guide to clamp the disk in place. Using a 3/32-inch bit, drill through the valve plug tip using the hole in the valve plug guide as a drilling guide. Remove any chips or burrs and drive in a new pin (key 31).

## Parts Ordering

Each valve is assigned a serial number, which can be found on the valve body. This same number also appears on the actuator nameplate when the valve is shipped from the factory as part of a control valve assembly. Refer to the serial number when contacting your CVS sales office for technical assistance.

**Table 3.** Recommended torques for Packing Flange Nuts (Not for Spring Loaded Packing)

Valve Stem Diameter		Pressure Rating	Graphite Type Packing				PTFE Type Packing				
			Minimum Torque		Maximum Torque		Minimum Torque		Maximum Torque		
			Nm	Lbf In	Nm	Lbf In	Nm	Lbf In	Nm	Lbf In	
9.5	3/8	CL125	3	27	5	40	1	13	2	19	
		CL150									
		CL250	4	36	6	53	2	17	3	26	
		CL300									
12.7	1/2	CL600	6	49	8	73	3	23	4	35	
		CL125	5	44	8	66	2	21	4	31	
		CL150									
		CL250	7	59	10	88	3	28	5	42	
19.1	3/4	CL300	9	81	14	122	4	39	7	58	
		CL600									
		CL125	11	99	17	149	5	47	8	70	
		CL150									
		CL250	15	133	23	199	7	64	11	96	
		CL300									
		CL600	21	182	31	274	10	87	15	131	

**Table 2.** Body to Bonnet Torque Guidelines

Valve Size	Torque			
	Bolt Material			
	SA193-B7		SA193-B8M (1)	
Inches	Lb•ft	Nm	Lb•ft	Nm
1	95	129	47	64
1-1/2 or 2	71	96	33	45

1.SA-193-B8M annealed

**CVS Design EZ – Plain and Extension Bonnet**

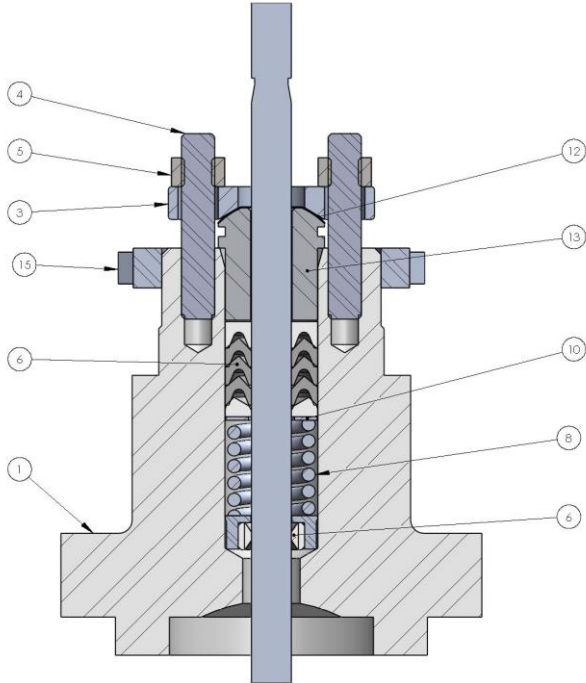

**Figure 11. Plain Bonnet**

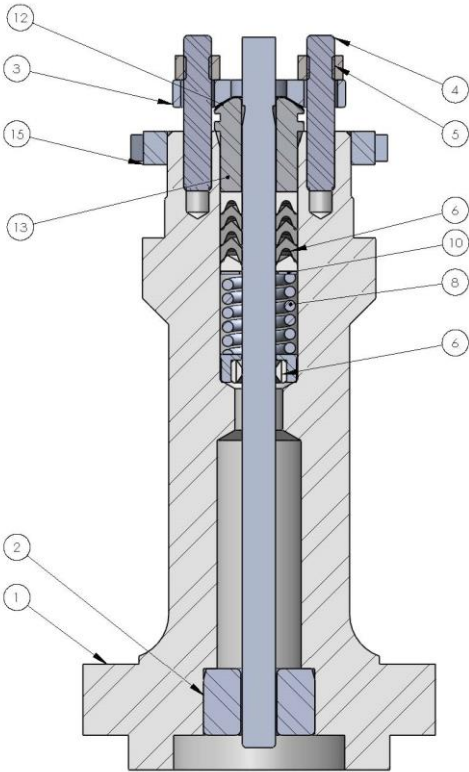

**Figure 12. Extension Bonnet**

## Parts List – Bonnet

Key	Description	Part Number
1	Bonnet, If you need a bonnet as a replacement part, order by valve size and Stem diameter, serial number, and desired material.	
2	Baffle, for extension bonnets only	
3	Packing Flange, S31600, (316 SST)	
4	Packing Flange Stud, S31600, (316 SST), 2 required	
5	Packing Flange Nut, S31600, (316 SST) 2 required	
6	Packing Set, PTFE, 2 required for double packing	
	9.5 mm (3/8 inch stem)	CVS1R290001012
	12.7 mm (1/2 inch stem)	CVS1R290201012
7	Packing Ring PTFE/Comp (for double packing)	
	9.5 mm (3/8 inch stem) PTFE/comp (7 required)	CVS1F3370X0012
	12.7 mm (1/2 inch stem)PTFE/comp (10 required)	CVS1E319001042
	19.1 mm (3/4 inch stem) PTFE/comp (8 required)	CVS1E319101042
8	Spring, S31600 (for single PTFE packing only)	
8	Spacer, N04400 (Monel) (for single PTFE pcking only)	
8	Lantern Ring (for double PTFE packing)	
10	Special Washer, S31600, (for single PTFE packing)	
11	Packing Box Ring, Single PTFE Packing	
	9.5 mm (3/8 inch) stem S31600 (standard for S31600 and S41600 trim)	CVS1J873135072
	N05500 (standard for N05500 trim)	CVS1J873146222
	12.7 mm (1/2 inch) stem S31600 (standard for S31600 and S41600 trim)	CVS1J873235072
	N05500 (standard for N05500 trim)	CVS1J873246222
11	19.1 mm (3/4 inch) stem S31600 (standard for S31600 and S41600 trim)	CVS1J873335072
	N05500 (standard for N05500 trim)	CVS1J873346222
	PTFE Composition Packing	
	9.5 mm (3/8 inch) stem S31600 (standard for S31600 and S41600 trim)	CVS1J873135072
11	Glass Filled PTFE (standard for N05500 trim)	CVS17A6872X012
	19.1 mm (3/4 inch) stem S31600 (standard for S31600 and S41600 trim)	CVS1J873335072
12	Glass Filled PTFE (standard for N05500 trim)	CVS17A6874X012
	Upper Wiper, felt	
	9.5 mm (3/8 inch) stem	CVS1J872606332
12	12.7 mm (1/2 inch) stem	CVS1J872706332
	19.1 mm (3/4 inch) stem	CVS1J872806332
13	Packing Follower	
14	Pipe Plug (not shown)	
14	Lubricator	
14	Lubricator/Isolating Valve	
15	Yoke Locknut	
16	Pipe Plug (not shown)	
27	Pipe Nipple, for lub/isolating valve,steel or equivalent (not furnished with valve)	

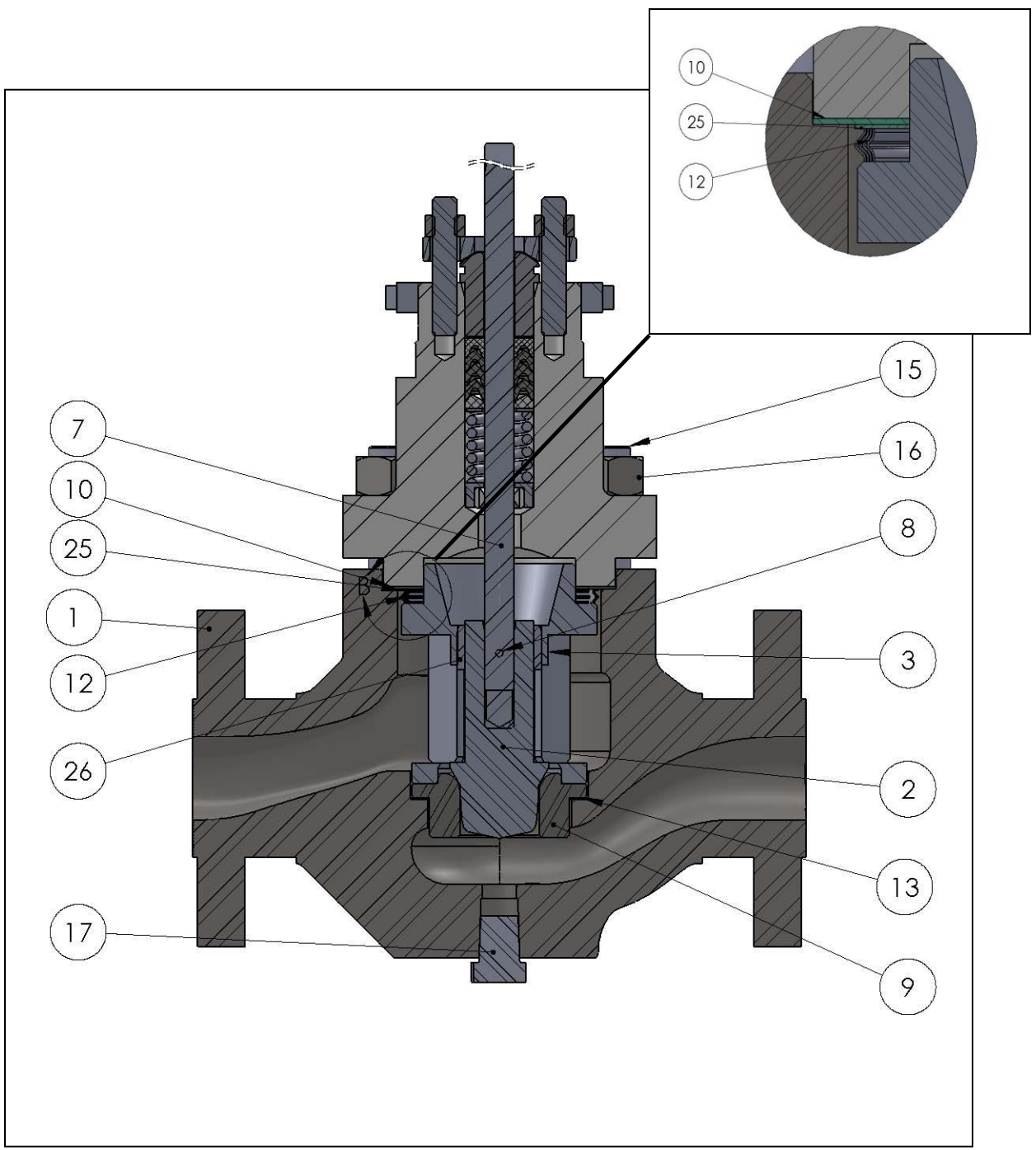

**Figure 13.** CVS Design EZ Control Valve

## Parts List – Valve Body

Key	Description	Part Number
1	Valve Body, Order by valve size, serial number and desired material	
2	Valve Plug	See following table
3	Seat Ring Retainer, (part numbers for seat ring ret./bushing assy. are provided on a following table 1/2, 3/4, and 1 inch valve, CB7Cu-1 (17-4PH-SST)	CVS25A6683X012
	CF8M (316 SST)	CVS25A6683X022
	M35-1 (Monel)	CVS25A6683X052
	1-1/2 inch valve, CB7Cu-1	CVS25A6685X012
	CF8M	CVS25A6685X022
	M35-1	CVS25A6685X052
	2 inch valve, CB7Cu-1	CVS25A6687X012
	CF8M	CVS25A6687X022
M35-1	CVS25A6687X052	
7	Stem	See following table
8	Pin	See following table
9	Seat Ring	See following table
10	Bonnet Gasket	See following table
12	Spiral Wound Gasket	See following table
13	Seat Ring Gasket	See following table
15	Cap Screw or Stud Bolt	
16	Nut	
17	Pipe Plug, for use in valve bodies with drain tapping only	
18	Flow Arrow, SST	
19	Drive Screw, SST, (4 required)	
25	Shim	See following table
26	Bushing, (see table for Bushing, Seat Ring Ret. Assy part numbers)	See following table
27	Valve Plug Guide, (for composition seats only)	See following table
28	Disk Retainer, (for composition seats only)	
	6.4 mm (1/4 inch) port diameter, S31600	CVS16A3441X012
	N05500	CVS16A3441X042
	S41600	CVS16A3441X052
	9.5 mm (3/8 inch) port diameter, S31600	CVS16A5706X012
	N05500	CVS16A5706X042
S41600	CVS16A5706X052	
29	Disk, PTFE (composition seats only)	
	6.4 mm (1/4 inch) port diameter	CVS13A1226X062
	9.5 mm (3/8 inch) port diameter	CVS13A5125X042
	12.7 mm (1/2 inch) port diameter	CVS1P696806242
	19.1 mm (3/4 inch) port diameter	CVS1P696106242
	25.4 mm (1 inch) port diameter	CVS1P696906242
	38.1 mm (1-1/2 inch) port diameter	CVS1U279606242
50.8 mm (2 inch) port diameter	CVS1U279906242	
30	Tip (composition seats only)	See following table
31	Pin (composition seats only)	
	12.7 mm (1/2 inch) port diameter, S31600, and S41600	CVS1B599038992
	N05500	CVS1B5990X0032
	19.1mm (3/4 inch) port diameter, S31600, and S41600	CVS1P730438992
	N05500	CVS1P7304X0032
	25.4 mm (1 inch), and 38.1 mm (1-1/2 inch)port diameter, S31600, and S41600	CVS1B599335072
	N05500	CVS1B5993X00B2
	50.8 mm (2 inch) port diameter, S31600, and S41600	CVS1B599538992
N05500	CVS1B599540032	
32	Cap Screw (composition seat only)	
33	Nameplate, stainless steel	
34	Wire, lead	

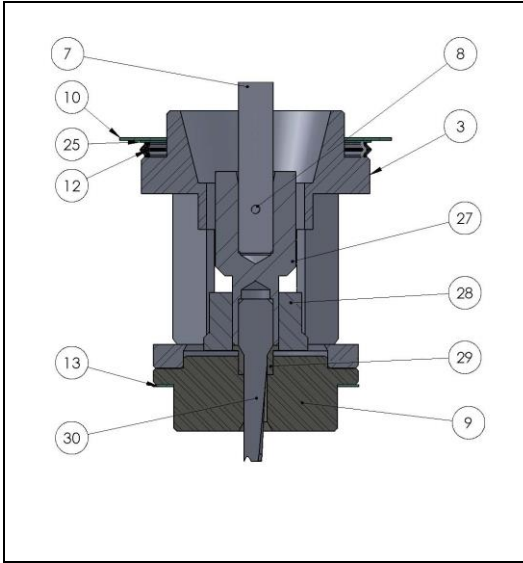

CVS M-Flute Valve Plug  
1/4" Port Diameter

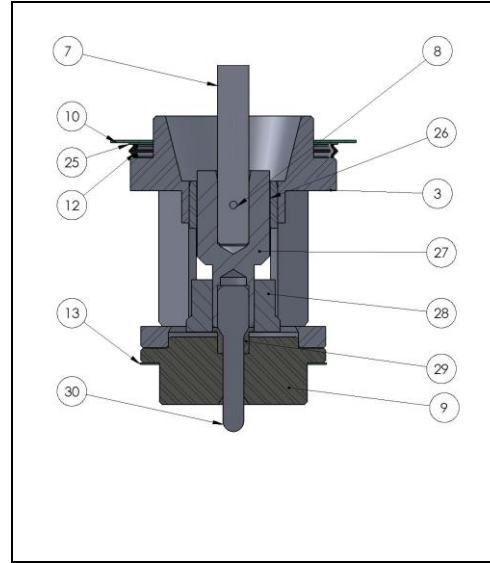

CVS M-Form Valve Plug  
1/4" & 3/8" Port Diameters

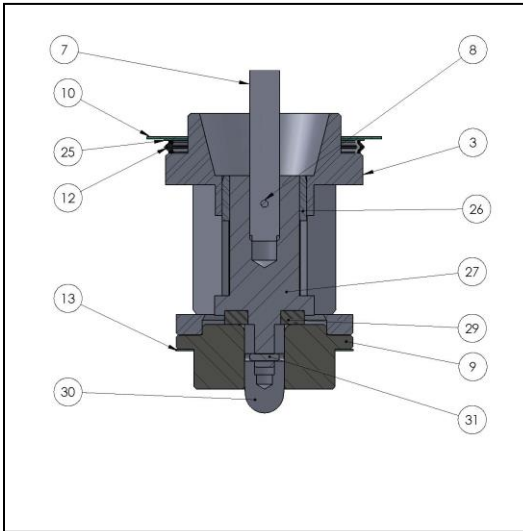

CVS M-Form Valve Plug  
1/2" – 1" Port Diameters

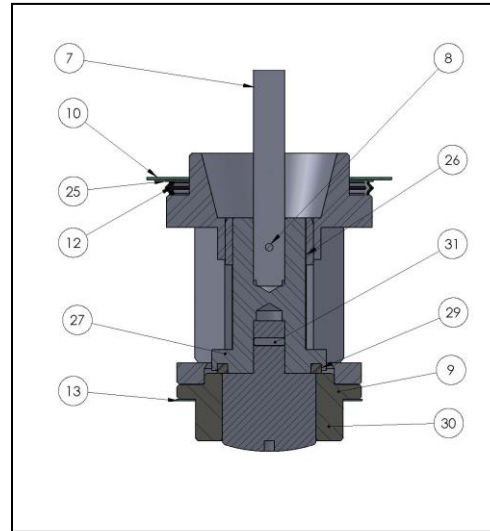

CVS Equal Percentage Valve Plug  
1-1/2" & 2" Port Diameters

**Figure 14.** Composition Seats for CVS Design EZ Control Valve

# Parts List

Key 2\* Equal Percentage (Including M-Form), Linear, and Quick-Opening Valve Plugs

VALVE SIZE, INCH	VALVE PLUG	PORT DIAMETER		VSC <sup>(1)</sup>		PLUG MATERIAL				
		mm	Inch	mm	Inch	S31600 (316 SST)	S31600 w/ CoCr-A (Alloy 6) Seat	S31600 w/ CoCr-A Seat & Guide	N05500 <sup>(2)</sup> (K-Monel)	S41600 (416 SST)
1/2, 3/4, 1, 1-1/2 & 2	M-Form	6.4	1/4	9.5	3/8	CVS15A6500X012	CVS15A6663X012	CVS15A6664X012	CVS15A6500X042	CVS15A6500X052
		9.5	3/8			CVS16A5708X012	CVS16A5713X012	CVS16A5711X012	CVS16A5708X042	CVS16A5708X052
		12.7	1/2			CVS15A6502X012	CVS15A6659X012	CVS15A6660X012	CVS15A6502X042	CVS15A6502X052
		19.1	3/4			CVS16A3335X012	CVS16A3337X012	CVS16A3339X012	CVS16A3335X042	CVS16A3335X052
		6.4	1/4	12.7	1/2	CVS15A6501X012	---	---	CVS15A6501X042	CVS15A6501X052
		9.5	3/8			CVS16A5709X012	CVS16A5714X012	CVS16A5712X012	CVS16A5709X042	CVS16A5709X052
		12.7	1/2			CVS15A6503X012	CVS15A6661X012	CVS15A6662X012	CVS15A6503X042	CVS15A6503X052
		19.1	3/4			CVS16A3336X012	CVS16A3338X012	CVS16A3340X012	CVS16A3336X042	CVS16A3336X052
	Quick Opening	25.4	1	9.5	3/8	CVS15A6490X012	CVS15A6516X012	CVS15A6517X012	CVS15A6490X042	CVS15A6490X052
				12.7	1/2	CVS15A6491X012	CVS15A6518X012	CVS15A6519X012	CVS15A6491X042	CVS15A6491X052
	Linear	25.4	1	9.5	3/8	CVS15A6470X012	CVS15A6614X012	CVS15A6615X012	CVS15A6470X042	CVS15A6470X052
				12.7	1/2	CVS15A6471X012	CVS15A6616X012	CVS15A6617X012	CVS15A6471X042	CVS15A6471X052
	Equal Percentage	25.4	1	9.5	3/8	CVS15A6480X012	CVS15A6634X012	CVS15A6635X012	CVS15A6480X042	CVS15A6480X052
				12.7	1/2	CVS15A6481X012	CVS15A6636X012	CVS15A6637X012	CVS15A6481X042	CVS15A6481X052
		38.1	1-1/2	9.5	3/8	CVS15A6492X012	CVS15A6520X012	CVS15A6521X012	CVS15A6492X042	CVS15A6492X052
				12.7	1/2	CVS15A6493X012	CVS15A6522X012	CVS15A6523X012	CVS15A6493X042	CVS15A6493X052

1. Valve stem connection.

2. Monel materials in hydrofluoric acid service require special options. Contact your CVS sales office for assistance.

\*M-Flat trim available upon request, contact a CVS Controls representative for more information.

Key 3\*, 26\* Seat Ring Retainer and Bushing Assembly<sup>(1) (2)</sup>

VALVE SIZE, INCH	SEAT RING RETAINER/BUSHING MATERIAL		
	CB7Cu-1/S17400 (17-4PH SST)	CF8M/R30006 (316 SST/Alloy 6)	M35-1/N05500 <sup>(3)</sup> (Monel/K-Monel)
1/2, 3/4, & 1	CVS25A6683X062	CVS25A6683X072	CVS25A6683X172
1-1/2	CVS25A6685X072	CVS25A6685X082	CVS25A6685X142
2	Full	CVS25A6687X062	CVS25A6687X112
	Restricted	CVS25A6687X092	CVS25A6687X132

1. Seat ring retainer (only) see parts list.

2. M flute constructions do not use bushings

# Parts List

Key 2\*, 7\*, and 8\* Valve Plug/Stem Assembly for Plain Bonnet

VALVE SIZE, INCH	VALVE PLUG	PORT DIA		VSC <sup>(1)</sup>		PLUG MATERIAL					
		mm	Inch	mm	Inch	S31600 (316 SST)	S31600 w/ CoCr-A (Alloy 6) Seat	S31600 w/ CoCr-A Seat & Guide	N05500 <sup>(2)</sup> (K-Monel)	S41600 (416 SST)	
1/2, 3/4, 1, 1-1/2, & 2	M-Flow	4.8	3/16					CVS2V9269X00A2		CVS1V1081X0142	
	M-Flute (1 flute)	6.4	1/4	9.5	3/8	---	---	CVS2U8682X0032	---	CVS1U8445X0032	
	M-Flute (3 flutes)	6.4	1/4					CVS2U8684X0032		CVS1U8447X00E2	
	M-Form	6.4	1/4	9.5	3/8	CVS15A6500X082	CVS15A6663X022	CVS15A6664X042	CVS15A6500X152	CVS15A6500X092	
		9.5	3/8			CVS16A5708X092	CVS16A5713X032	CVS16A5711X022	CVS16A5708X182	CVS16A5708X112	
		12.7	1/2			CVS15A6502X072	CVS15A6659X022	CVS15A6660X042	CVS15A6502X102	CVS15A6502X112	
		19.1	3/4			CVS16A3335X112	CVS16A3337X042	CVS16A3339X022	CVS16A3335X212	CVS16A3335X132	
		6.4	1/4	12.7	1/2 x 3/8	---	---	CVS15A6664X022	---	CVS15A6500X252	
		9.5	3/8			---	---	CVS16A5711X042	---	CVS16A5708X132	
		12.7	1/2			CVS15A6502X162	CVS15A6659X082	CVS15A6660X082	---	CVS15A6502X152	
		19.1	3/4			CVS16A3335X142	CVS16A3337X032	CVS16A3339X092	---	CVS16A3335X182	
	Quick Opening	25.4	1	9.5	3/8	---	CVS15A6516X022	CVS15A6517X022	---	CVS15A6490X092	
				12.7	1/2 x 3/8	---	---	---	---	CVS15A6490X072	
	Linear	25.4	1	9.5	3/8	CVS15A6470X092	---	CVS15A6615X022	---	CVS15A6470X102	
				12.7	1/2 x 3/8	CVS15A6470X072	---	CVS15A6615X032	---	CVS15A6470X122	
	Equal Percentage	25.4	1	9.5	3/8	CVS15A6480X102	CVS15A6634X042	CVS15A6635X022	CVS15A6480X152	CVS15A6480X112	
				12.7	1/2 x 3/8	CVS15A6480X202	CVS15A6634X072	CVS15A6635X042	---	CVS15A6480X172	
	1-1/2	Quick Opening	38.1	1-1/2	9.5	3/8	CVS15A6492X102	CVS15A6520X032	CVS15A6521X022	---	CVS15A6492X082
		Linear					CVS15A6472X132	---	CVS15A6619X022	---	CVS15A6472X072
		Equal Percentage					CVS15A6482X102	CVS15A6638X032	CVS15A6639X022	---	CVS15A6482X112
2	Quick Opening	50.8	2	12.7	1/2	CVS15A6494X082	---	CVS15A6525X022	---	CVS15A6494X072	
	Linear					CVS15A6474X132	---	CVS15A6623X022	---	CVS15A6474X072	
	Equal Percentage					CVS15A6484X072	CVS15A6642X042	CVS15A6643X032	CVS15A6484X102	CVS15A6484X112	

1. Valve stem connection.

2. Monel materials in hydrofluoric acid service require special options. Contact your CVS sales office for assistance.

## Key 7\* Stem

VALVE SIZE, INCH	STEM DIAMETER		STEM MATERIAL		
	mm	Inch	S31600	N05500	Nitronic 50 (NACE)
1/2, 3/4, 1, 1-1/2	9.5	3/8	CVS1U388835162	CVS10A8823XA22	CVS1U3888X0222
	12.7	1/2	CVS1U388935162	CVS1U3889X0012	CVS1U3889X0042
	12.7 x 9.5	1/2 x 3/8	CVS1U530935162	CVS1U530946222	CVS1U5309X0082
2	12.7	1/2	CVS1U388935162	CVS1U3889X0012	CVS1U3889X0042
	12.7 X 9.5	1/2 X 3/8	CVS1U530935162	CVS1U530946222	CVS1U5309X0082
	19.1	3/4	CVS1U226535162	CVS1U226550192	CVS1U2265X0042

# Parts List

## Key 8\* Pin

VALVE SIZE, INCH	VALVE PLUG STYLE	VSC <sup>(1)</sup>		PIN MATERIAL	
		mm	Inch	S31600 (316 SST)	N04400 (Monel) <sup>(2)</sup>
1/2 thru 2	M-Flow & M-Flute w/ metal seats	9.5	3/8	CVS1B599235072	CVS1B599240032
	M-Flute w/comp seats & M-Form	9.5 12.7	3/8 1/2	CVS1B599335072 CVS1D5423X00B2	CVS1B5993X00B2 CVS1D5423X0012
1/2 thru 1-1/2	Linear, Equal Percentage & Quick Opening	9.5	3/8	CVS1B599335072	CVS1B5993X00B2
		12.7	1/2	CVS1D5423X00B2	CVS1D5423X0012
2	Linear, Equal Percentage & Quick Opening (full cap)	12.7	1/2	CVS1B599835072	CVS1B599840032
		19.1	3/4	CVS1B813635072	CVS1B8136X0102
	Linear, Equal Percentage & Quick Opening (restricted port)	9.5	3/8	CVS1B599335072	CVS1B5993X00B2
		12.7	1/2	CVS1D5423X00B2	CVS1D5423X0012

1. Valve stem connection.

2. Monel materials in hydrofluoric acid service require special options. Contact your CVS sales office for assistance.

## Key 9\* Seat Ring (non-vaned) for Metal Seats

VALVE SIZE, INCH	PORT DIA		S31600 (316 SST)	S31600 w/ CoCr-A (ALLOY 6) SEAT	S31600 w/ CoCr-A SEAT & BORE	(1) N05500 (K-MONEL)	S41600 (416 SST)
	mm	Inch					
1/2, 3/4, and 1	4.8	3/16	CVS1V108335072	CVS2V626250332	CVS25A5710X012	CVS1V108346222	CVS1V108346172
	6.4	1/4	CVS1U285235072	CVS2U855946052	CVS25A5711X012	CVS1U285246222	CVS1U285246172
	9.5	3/8	CVS1U285335072	CVS2U856046052	CVS1U2853X0012	CVS1U285346222	CVS1U285346172
	12.7	1/2	CVS1U285435072	CVS2U856146052	CVS26A0651X012	CVS1U825446222	CVS1U285446172
	19.1	3/4	CVS1U285535072	CVS2U856246052	---	CVS1U2855X0092	CVS1U285546172
	25.4	1	CVS1U285635072	CVS2U856346052	---	CVS1U285646222	CVS1U285646172
1-1/2	4.8	3/16	CVS15A6512X012	CVS25A8564X012	CVS25A6536X012	CVS15A6512X042	CVS15A6512X052
	6.4	1/4	CVS15A6513X012	CVS15A6537X012	CVS25A6539X012	CVS15A6513X042	CVS15A6513X052
	9.5	3/8	CVS17A6075X012	CVS27A6076X012	CVS27A6079X012	CVS17A6075X042	CVS17A6075X052
	12.7	1/2	CVS15A6514X012	CVS15A6538X012	CVS26A0653X012	CVS15A6514X042	CVS15A6514X052
	19.1	3/4	CVS16A3350X012	CVS26A3351X012	CVS26A3352X012	CVS16A3350X042	CVS16A3350X052
	25.4	1	CVS15A6515X012	CVS15A6654X012	---	CVS15A6515X042	CVS15A6515X052
	38.1	1-1/2	CVS15A6504X012	CVS15A6655X012	---	CVS15A6504X042	CVS15A6504X052
2	4.8	3/16	CVS15A6692X012	CVS25A8565X012	CVS25A6696X012	CVS15A6692X042	CVS15A6692X052
	6.4	1/4	CVS15A6693X012	CVS25A6698X012	CVS25A6697X012	CVS15A6693X042	CVS15A6693X052
	9.5	3/8	CVS17A4091X022	CVS27A6080X012	CVS27A6081X012	CVS17A4091X052	CVS17A4091X012
	12.7	1/2	CVS15A6694X012	CVS25A6699X012	CVS26A0656X012	CVS15A6694X042	CVS15A6694X052
	19.1	3/4	CVS16A3353X012	CVS26A3354X012	CVS26A3355X012	CVS16A3353X042	CVS16A3353X052
	25.4	1	CVS15A6695X012	CVS25A1085X012	---	CVS15A6695X042	CVS15A6695X052
	50.8	2	CVS15A6505X012	CVS15A6656X012	---	CVS15A6505X042	CVS15A6505X052

1. Monel materials in hydrofluoric acid service require special options. Contact your CVS sales office for assistance.

## Parts List

### Key 9\* Seat Ring for Composition Seats

VALVE SIZE, INCH	PORT DIAMETER		S31600 (316 SST)	N05500 <sup>(1)</sup> (K-MONEL)	S41600 (416 SST)
	mm	Inch			
1/2, 3/4, & 1	6.4	1/4	CVS13A5872X012	CVS13A5872X062	CVS13A5872X022
	9.5	3/8	CVS13A5873X012	CVS13A5873X062	CVS13A5873X032
1-1/2	6.4	1/4	CVS16A3467X012	CVS16A3467X042	CVS16A3467X052
	9.5	3/8	CVS17A6078X012	CVS17A6078X042	CVS17A6078X052
2	6.4	1/4	CVS16A3468X012	CVS16A3468X042	CVS16A3468X052
	9.5	3/8	CVS17A6077X012	CVS17A6077X042	CVS17A6077X052

1. Monel materials in hydrofluoric acid service require special options. Contact your CVS sales office for assistance.

### Key 10\* Bonnet Gasket

### Key 12\* Spiral Wound Gasket

### Key 13\* Seat Ring Gasket

### Key 25\* Shim

Valve Size, Inch	Key Number	Gasket Set 2 <sup>(1)</sup>	Gasket Set 3 <sup>(1)</sup>	Gasket Set 4 <sup>(1)</sup>
1/2 - 3/4 & 1	Set	CVSRGASKETX162	CVS10A8170X042	---
	10	CVS1R2859X0042	CVS10A8163X012	CVS1R2859X0042
	12	CVS1R286099442	CVS10A8184X012	CVS1R286099292
	13	CVS1R2862X0062	CVS10A8177X012	CVS1R2862X0062
	25	CVS16A1936X012	CVS16A1936X022	CVS16A1936X022
1-1/2	Set	CVSRGASKETX172	CVS10A8171X032	---
	10	CVS1R3101X0032	CVS10A8164X012	CVS1R3101X0032
	12	CVS1R309999442	CVS10A8185X012	CVS1R309999292
	13	CVS1R3098X0052	CVS10A8178X012	CVS1R3098X0052
	25	CVS16A1937X012	CVS16A1937X022	CVS16A1937X022
2	Set	CVSRGASKETX182	CVS10A8172X032	---
	10	CVS1R3299X0042	CVS10A8165X012	CVS1R3299X0042
	12	CVS1R329799442	CVS10A8186X012	CVS1R329799292
	13	CVS1R3296X0042	CVS10A8179X042	CVS1R3296X0042
	25	CVS16A1938X012	CVS16A1938X022	CVS16A1938X022

1. See table below for description of gasket sets.

2. Consult your CVS sales office for gasket set part number.

### Gasket Selection Criteria

Gasket Set	Spiral				Temperature Capabilities
	Seat Ring Gasket	Bonnet Gasket	Wound Gasket	Shim	
2 <sup>(1)</sup>	316 SST/graphite flat sheet	316 SST/graphite flat sheet	N06600 (Inconel)/ graphite	S31600	-198 to 593_C (-325 to 1100_F)

1. FGM gasket set.

# Parts List

## Key 26\* Bushing

Valve Size, Inch	S17400 (17-4PH SST)	Alloy 6	N05500 (K-Monel) <sup>(1)</sup>
1/2, 3/4, & 1	CVS15A6508X012	CVS15A6508X022	CVS15A6508X052
1-1/2	CVS15A7511X012	CVS15A7511X022	CVS15A7511X052
2 (rest. port)	CVS15A6509X012	CVS15A6509X022	CVS15A6509X052
2 (full port)	CVS15A6510X012	CVS15A6510X022	CVS15A6510X052

1. Monel materials in hydrofluoric acid service require special options. Contact your CVS sales office for assistance.

## Key 27\* Valve Plug Guide (composition seat only)

VALVE PLUG	VALVE STEM CONNECTION		PORT DIA		MATERIAL			
	mm	Inch	mm	Inch	S31600 (316 SST)	N05500 <sup>(1)</sup> (K-Monel)	S41600 (416 SST)	S31600 w/CoCr-A (Alloy 6)
M-Flute	9.5	3/8	6.4	1/4	CVS16A3440X012	CVS16A3440X042	---	CVS19A5814X012
M-Form	9.5	3/8	6.4	1/4	CVS16A3440X012	CVS16A3440X042	CVS16A3440X052	CVS19A5814X012
			9.5	3/8	CVS16A5703X012	CVS16A5703X042	CVS16A5703X052	CVS19A5815X012
			12.7	1/2	CVS16A3445X012	CVS16A3445X042	CVS16A3445X052	CVS17A7250X012
			19.1	3/4	CVS26A3449X012	CVS26A3449X042	CVS26A3449X052	CVS28A8115X012
	12.7	1/2	9.5	3/8	CVS16A5707X012	CVS16A5707X042	CVS16A5707X052	CVS19A5815X012
			12.7	1/2	CVS16A3446X012	CVS16A3446X042	CVS16A3446X052	CVS19A5817X012
			19.1	3/4	CVS26A3450X012	CVS26A3450X042	CVS26A3450X052	CVS29A5812X012
			25.4	1	CVS26A3453X012	CVS26A3453X042	CVS26A3453X052	CVS29A5806X012
Equal Percentage	12.7	1/2	25.4	1	CVS26A3454X012	CVS26A3454X042	CVS26A3454X052	CVS29A5807X012
	9.5	3/8	38.1	1-1/2	CVS26A3457X012	CVS26A3457X042	CVS26A3457X052	CVS28A1253X012
	12.7	1/2	50.8	2	CVS26A3460X012	CVS26A3460X042	CVS26A3460X052	CVS29A5813X012
	12.7	1/2	76.2	3	CVS26A3470X012	CVS26A3470X042	CVS26A3470X052	CVS29A5811X012
	19.1	3/4	76.2	3	CVS26A3471X012	CVS26A3471X042	CVS26A3471X052	CVS29A5810X012
	12.7	1/2	102	4	CVS26A3463X012	CVS26A3463X042	CVS26A3463X052	CVS29A5808X012
	19.1	3/4	102	4	CVS26A3464X012	CVS26A3464X042	CVS26A3464X052	CVS29A5809X012

1. Monel materials in hydrofluoric acid service require special options. Contact your CVS sales office for assistance.

## Key 30\* Tip

VALVE SIZE, INCH	VALVE PLUG	PORT DIA		VALVE STEM CONNECTION		MATERIAL			
		mm	Inch	mm	Inch	S31600 (316 SST)	Alloy 6	N05500 <sup>(1)</sup> (K-Monel)	S41600 (416 SST)
1/2, 3/4, 1, 1-1/2, & 2	M-Flute (1 flute)	6.4	1/4	9.5	3/8	---	CVS13A5863X032	CVS13A5863X042	---
	M-Flute (3 flutes)					---	CVS13A5865X032	CVS13A5865X022	---
	M-Form	6.4	1/4	9.5	3/8	CVS13A6160X022	---	CVS13A6160X062	CVS13A6160X012
						CVS16A5704X012	---	CVS16A5704X042	CVS16A5704X052
						CVS1R9537X0022	---	CVS1R9537X0062	CVS1R9537X0012
						CVS1R9540X0012	---	CVS1R9540X0072	CVS1R9540X0042
		9.5	3/8	12.7	1/2	CVS16A5704X012	---	CVS16A5704X042	CVS16A5704X052
						CVS1R9537X0022	---	CVS1R9537X0062	CVS1R9537X0012
	19.1	3/4	12.7	1/2	CVS1R9540X0012	---	CVS1R9540X0072	CVS1R9540X0042	
	Equal Percentage	25.4	1	9.5 & 12.7	3/8 & 1/2	CVS1R953835072	---	CVS1R9538X0032	CVS1R9538X0012
		38.1	1-1/2	9.5	3/8	CVS16A3458X012	---	CVS16A3458X042	CVS16A3458X052
		50.8	2	12.7	1/2	CVS12A3889X012	---	CVS12A3889X042	CVS12A3889X052

1. Monel materials in hydrofluoric acid service require special options. Contact your CVS sales office for assistance.

# CVS Design EZ – Product Bulletin

## Quick Open - Flow Up - CVS Design EZ, Quick Opening Valve Plug

Valve Size, NPS	Port Diameter		Maximum Travel		Flow Coefficient	Cv for .25 Inch (6mm) Travel(1)	Valve Opening—Percent of Total Travel										FL(2)
	Inches	mm	Inches	mm			10	20	30	40	50	60	70	80	90	100	
1	1	25.4	0.75	19	Cv	14.7	4.39	10.3	14.0	15.5	16.2	16.6	16.8	16.8	16.9	16.9	0.94
					Kv	12.7	3.80	8.91	12.1	13.4	14.0	14.4	14.5	14.5	14.6	14.6	--
					XT	14.7	0.400	0.449	0.523	0.539	0.535	0.512	0.500	0.500	0.494	0.494	---
					Fd	--	0.20	0.29	0.39	0.48	0.50	0.50	0.50	0.50	0.50	0.50	--
1-1/2	1.5	38.1	0.75	19	Cv	22.6	5.64	11.9	20.6	27.4	30.5	32.4	33.4	33.7	34.1	34.2	0.96
					Kv	19.5	4.88	10.3	17.8	23.7	26.4	28.0	28.9	29.2	29.5	29.6	--
					XT	22.6	0.623	0.734	0.726	0.814	0.843	0.857	0.861	0.860	0.853	0.848	---
					Fd	--	0.16	0.24	0.32	0.39	0.45	0.50	0.50	0.50	0.50	0.50	--
	1(4)	25.4(4)	0.75	19	Cv	15.7	4.17	8.94	14.6	17.4	18.3	18.8	18.9	19.0	19.1	19.4	0.90
					Kv	13.6	3.61	7.73	12.6	15.1	15.8	16.3	16.3	16.4	16.5	16.8	--
2	2	50.8	1.125	29	Cv	34.0	13.0	30.1	44.3	52.4	56.4	57.8	58.4	58.5	58.6	58.6	0.94
					Kv	29.4	11.2	26.0	38.3	45.3	48.8	50.0	50.5	50.6	50.7	50.7	--
					XT	34.0	0.548	0.663	0.765	0.813	0.818	0.833	0.831	0.836	0.834	0.834	---
					Fd	--	0.17	0.28	0.36	0.43	0.49	0.50	0.50	0.50	0.50	0.50	--
	1(4)	25.4(4)	0.75	19	Cv	15.8	4.35	9.79	14.9	16.6	17.3	17.5	17.5	17.6	17.7	17.9	0.86
					Kv	13.7	3.76	8.47	12.9	14.4	15.0	15.1	15.1	15.2	15.3	15.5	--
					XT	15.8	0.524	0.594	0.695	0.877	0.937	0.944	0.958	0.952	0.942	0.921	--
					Fd	--	0.17	0.27	0.35	0.42	0.47	0.50	0.50	0.50	0.50	0.50	--
3	3	76.2	1.5	38	Cv	53.8	30.8	65.1	92.4	110	118	123	126	128	129	129	0.91
					Kv	46.5	26.6	56.3	79.9	95.2	102	106	109	111	112	112	--
					XT	53.8	0.672	0.714	0.713	0.742	0.784	0.785	0.783	0.776	0.774	0.774	---
					Fd	--	0.17	0.27	0.35	0.42	0.47	0.50	0.50	0.50	0.50	0.50	--
	2(4)	50.8(4)	1.125	29	Cv	32.2	9.99	27.6	44.9	61.0	71.9	78.4	83.1	86.2	87.5	88.4	0.95
					Kv	27.9	8.64	23.9	38.8	52.8	62.2	67.8	71.9	74.6	75.7	76.5	--
					XT	32.2	0.527	0.511	0.652	0.720	0.780	0.820	0.814	0.798	0.790	0.779	--
					Fd	--	0.18	0.28	0.36	0.42	0.48	0.50	0.50	0.50	0.50	0.50	--
4	4	101.6	2	51	Cv	68.2	50.8	116	159	185	201	212	219	222	223	223	0.88
					Kv	59.0	43.9	100	138	160	174	183	189	192	193	193	--
					XT	68.2	0.733	0.653	0.724	0.805	0.809	0.816	0.809	0.812	0.831	0.835	---
					Fd	--	0.18	0.28	0.36	0.42	0.48	0.50	0.50	0.50	0.50	0.50	--
	2(4)	50.8(4)	1.125	29	Cv	37.4	13.5	32.3	52.2	66.2	74.4	81.1	85.0	85.8	86.3	86.7	0.85
					Kv	32.4	11.7	27.9	45.2	57.3	64.4	70.2	73.5	74.2	74.6	75.0	--
					XT	37.4	0.490	0.556	0.609	0.672	0.793	0.772	0.728	0.714	0.711	0.704	--
					Fd	--	0.18	0.28	0.36	0.42	0.48	0.50	0.50	0.50	0.50	0.50	--

1. Self operated regulators
2. At 100% travel
3. Restricted Trim

## CVS Design EZ – Product Bulletin

Linear - Flow Up – CVS Design EZ, Linear Valve Plug																
Valve Size, NPS	Port Diameter		Maximum Travel(1)		Flow Coefficient	Valve Opening–Percent of Total ravel										FL(1)
	Inches	mm	Inches	mm		10	20	30	40	50	60	70	80	90	100	
1	1	25.4	0.75	19	Cv	2.21	3.87	5.29	6.56	8.2	9.82	11.1	12.1	13.0	13.6	0.96
					Kv	1.91	3.35	4.58	5.67	7.09	8.49	9.60	10.5	11.2	11.8	--
					XT	0.638	0.601	0.638	0.634	0.638	0.629	0.636	0.680	0.769	0.834	--
1-1/2	1.5	38.1	0.75	19	Cv	3.99	7.53	11.1	14.8	18.7	22.5	25.8	29.2	31.2	31.9	0.96
					Kv	3.45	6.51	9.6	12.8	16.2	19.5	22.3	25.3	27.0	27.6	--
					XT	0.633	0.651	0.657	0.691	0.674	0.674	0.696	0.704	0.757	0.818	--
	1 (2)	25.4 (2)	0.75	19	Cv	1.96	3.42	4.94	6.11	7.8	9.3	10.9	13	15.1	16.7	0.96
					Kv	1.70	2.96	4.27	5.29	6.75	8.04	9.43	11.2	13.1	14.4	--
					XT	0.469	0.578	0.600	0.690	0.652	0.655	0.637	0.625	0.719	0.796	--
2	2	50.8	1.125	29	Cv	6.08	11.9	18.0	24.1	30.1	36.4	42.8	49.9	52.0	52.4	0.95
					Kv	5.26	10.3	15.6	20.8	26.0	31.5	37.0	43.2	45.0	45.3	--
					XT	0.560	0.644	0.655	0.675	0.701	0.724	0.779	0.773	0.862	0.924	--
	1 (2)	25.4 (2)	0.75	19	Cv	1.88	3.41	4.95	6.49	8.06	9.67	11.23	12.79	14.35	15.7	0.94
					Kv	1.63	2.95	4.28	5.61	6.97	8.36	9.71	11.1	12.4	13.6	--
					XT	0.609	0.593	0.597	0.624	0.621	0.626	0.642	0.633	0.750	0.910	--
3	3	76.2	1.5	38	Cv	15.4	29.6	43.4	58.3	71.8	83.9	93.8	103	108	110.4	0.92
					Kv	13.3	25.6	37.5	50.4	62.1	72.6	81.1	89.1	93.4	95.5	--
					XT	0.622	0.642	0.692	0.691	0.690	0.721	0.759	0.788	0.839	0.888	--
	2 (2)	50.8 (2)	1.125	29	Cv	6.59	13.3	20.7	28.1	36.0	44.0	55.6	67.5	76.2	80.4	0.94
					Kv	5.70	11.5	17.9	24.3	31.1	38.1	48.1	58.4	65.9	69.5	--
					XT	0.564	0.500	0.522	0.609	0.577	0.594	0.563	0.582	0.677	0.749	--
4	4	101.6	2	51	Cv	21.3	39.7	57.5	75.8	100	129	157	180	199	209	0.89
					Kv	18.4	34.3	49.7	65.6	86.5	112	136	156	172	181	--
					XT	0.554	0.628	0.684	0.723	0.665	0.608	0.677	0.826	0.862	0.866	--
	2 (2)	50.8 (2)	1.125	29	Cv	6.16	12.8	20.0	27.8	36.1	45.1	58.8	67.5	78.8	86.8	0.90
					Kv	5.33	11.1	17.3	24.0	31.2	39.0	50.9	58.4	68.2	75.1	--
					XT	0.740	0.644	0.642	0.619	0.602	0.605	0.552	0.614	0.644	0.736	--

1. At 100% travel

2. Restricted trim

## CVS Design EZ – Product Bulletin

Equal Percentage - Flow Up – CVS Design EZ, Equal Percent Valve Plug																
Valve Size, NPS	Port Diameter		Maximum Travel		Flow Coefficient	Valve Opening–Percent of Total Travel										FL(1)
	Inches	mm	Inches	mm		10	20	30	40	50	60	70	80	90	100	
1	1	25.4	0.75	19	Cv	0.79	1.25	1.80	2.53	3.63	5.28	7.59	10.7	12.7	13.2	0.96
					Kv	0.683	1.08	1.56	2.19	3.14	4.57	6.57	9.26	11.0	11.4	--
					XT	0.641	0.634	0.598	0.586	0.584	0.596	0.646	0.680	0.757	0.886	---
					Fd	0.091	0.11	0.13	0.16	0.19	0.24	0.30	0.37	0.43	0.50	--
1-1/2	1.5	38.1	0.75	19	Cv	0.795	1.23	1.91	2.95	4.30	6.46	9.84	16.4	22.2	28.1	0.97
					Kv	0.688	1.06	1.65	2.55	3.72	5.59	8.51	14.2	19.2	24.3	--
					XT	0.726	0.676	0.733	0.645	0.589	0.558	0.597	0.653	0.777	0.840	---
					Fd	0.077	0.086	0.10	0.12	0.15	0.17	0.22	0.27	0.34	0.40	--
	1 (2)	25.4 (2)	0.75	19	Cv	0.770	1.23	1.78	2.58	3.67	5.54	8.30	12.0	15.1	17.3	0.98
					Kv	0.666	1.06	1.54	2.23	3.17	4.79	7.18	10.4	13.1	15.0	--
					XT	0.654	0.619	0.601	0.605	0.561	0.534	0.518	0.575	0.704	0.861	--
					Fd	0.069	0.085	0.11	0.13	0.18	0.23	0.30	0.37	0.44	0.50	--
2	2	50.8	1.125	29	Cv	1.65	2.61	4.30	6.62	11.1	20.7	32.8	44.7	50.0	53.8	0.95
					Kv	1.43	2.26	3.72	5.73	9.60	17.9	28.4	38.7	43.3	46.5	--
					XT	0.655	0.581	0.520	0.559	0.552	0.529	0.653	0.801	0.903	0.899	---
					Fd	0.069	0.085	0.11	0.13	0.18	0.23	0.30	0.37	0.44	0.50	--
	1 (2)	25.4 (2)	0.75	19	Cv	1.02	1.50	2.05	2.78	3.90	5.57	8.16	11.8	14.5	15.9	0.92
					Kv	0.882	1.30	1.77	2.40	3.37	4.82	7.06	10.2	12.5	13.8	--
					XT	0.596	0.616	0.600	0.580	0.572	0.555	0.523	0.547	0.671	0.905	--
					Fd	0.062	0.081	0.10	0.12	0.16	0.20	0.26	0.33	0.40	0.46	--
3	3	76.2	1.5	38	Cv	3.11	5.77	9.12	13.7	21.7	36.0	60.4	86.4	104	114	0.92
					Kv	2.69	4.99	7.89	11.9	18.8	31.1	52.2	74.7	90.0	98.6	--
					XT	0.619	0.595	0.598	0.619	0.594	0.563	0.586	0.729	0.778	0.781	---
					Fd	0.062	0.081	0.10	0.12	0.16	0.20	0.26	0.33	0.40	0.46	--
	2 (2)	50.8 (2)	1.125	29	Cv	2.11	3.11	4.58	6.76	10.7	20.7	34.3	48.3	61.5	71.6	0.92
					Kv	1.83	2.69	3.96	5.85	9.26	17.9	29.7	41.8	53.2	61.9	--
					XT	0.874	0.699	0.643	0.626	0.587	0.451	0.493	0.587	0.648	0.734	--
					Fd	0.052	0.065	0.080	0.10	0.13	0.17	0.23	0.31	0.38	0.44	--
4	4	101.6	2	51	Cv	4.90	8.19	13.5	20.1	31.2	52.6	96.7	140	170	190	0.90
					Kv	4.24	7.08	11.7	17.4	27.0	45.5	83.6	121	147	164	--
					XT	0.594	0.573	0.560	0.568	0.572	0.564	0.532	0.707	0.807	0.834	---
					Fd	0.052	0.065	0.080	0.10	0.13	0.17	0.23	0.31	0.38	0.44	--
	2 (2)	50.8 (2)	1.125	29	Cv	1.96	3.05	4.43	6.98	11.9	22.3	36.7	50.9	61.8	72.7	0.92
					Kv	1.70	2.64	3.83	6.04	10.3	19.3	31.7	44.0	53.5	62.9	--
					XT	0.619	0.575	0.624	0.610	0.678	0.639	0.646	0.673	0.778	0.781	--
					Fd	0.052	0.065	0.080	0.10	0.13	0.17	0.23	0.31	0.38	0.44	--

1. At 100% travel

2. Restricted trim

## CVS Design EZ – Product Bulletin

### M-Form - Flow Up – CVS Design EZ, Equal Percentage Characteristic

Valve Size, NPS	Port Diameter		Maximum Travel		Flow Coefficient	Valve Opening—Percent of Total Travel											FL(1)
	Inches	mm	Inches	mm		5	10	20	30	40	50	60	70	80	90	100	
All Sizes 1 1-1/2 2	0.25	6.4	0.75	19	Cv	0.075	0.088	0.124	0.175	0.236	0.327	0.464	0.641	0.881	1.22	1.52	0.88
					Kv	0.065	0.076	0.107	0.151	0.204	0.283	0.401	0.554	0.762	1.06	1.31	--
					XT	0.804	0.771	0.717	0.658	0.645	0.620	0.585	0.596	0.596	0.603	0.647	--
1	0.375	9.5	0.75	19	Cv	0.099	0.129	0.199	0.308	0.448	0.620	0.882	1.29	1.80	2.43	3.07	0.89
					Kv	0.086	0.112	0.172	0.266	0.388	0.536	0.763	1.12	1.56	2.10	2.66	--
					XT	0.795	0.747	0.663	0.641	0.593	0.569	0.568	0.560	0.571	0.624	0.662	--
	0.5	12.7	0.75	19	Cv	0.133	0.189	0.319	0.492	0.735	1.08	1.53	2.12	2.99	4.17	4.91	0.93
					Kv	0.115	0.163	0.276	0.426	0.636	0.934	1.32	1.83	2.59	3.61	4.25	--
					XT	0.787	0.728	0.639	0.628	0.591	0.573	0.585	0.600	0.618	0.645	0.803	--
	0.75	19.1	0.75	19	Cv	0.276	0.374	0.622	0.965	1.47	2.17	3.15	4.57	6.52	8.17	8.84	0.97
					Kv	0.239	0.324	0.538	0.835	1.27	1.88	2.72	3.95	5.64	7.07	7.65	--
					XT	0.723	0.687	0.614	0.588	0.560	0.571	0.596	0.603	0.624	0.750	0.919	--
1-1/2 and 2	0.375	9.5	0.75	19	Cv	0.096	0.121	0.190	0.302	0.435	0.600	0.864	1.26	1.80	2.56	3.20	0.84
					Kv	0.083	0.105	0.164	0.261	0.376	0.519	0.747	1.09	1.56	2.21	2.77	--
					XT	0.923	0.915	0.763	0.699	0.657	0.640	0.624	0.608	0.596	0.594	0.648	--
	0.5	12.7	0.75	19	Cv	0.145	0.199	0.323	0.503	0.735	1.07	1.54	2.14	3.08	4.36	5.18	0.91
					Kv	0.125	0.172	0.279	0.435	0.636	0.926	1.33	1.85	2.66	3.77	4.48	--
					XT	0.851	0.748	0.686	0.640	0.617	0.627	0.602	0.607	0.607	0.573	0.705	--
	0.75	19.1	0.75	19	Cv	0.336	0.434	0.683	1.00	1.49	2.21	3.18	4.61	6.73	8.88	10.2	0.92
					Kv	0.291	0.375	0.591	0.865	1.29	1.91	2.75	3.99	5.82	7.68	8.82	--
					XT	0.784	0.747	0.625	0.636	0.596	0.578	0.603	0.593	0.591	0.680	0.796	--

1. At 100% travel

## CVS Design EZ – Product Bulletin

### M-Flute - Flow Up – CVS Design EZ, Equal Percentage Characteristic

Valve Size, NPS	Port Diameter		Maximum Travel		Flow Coefficient	Valve Opening–Percent of Total Travel										FL(1)
	mm	Inches	mm	Inches		10	20	30	40	50	60	70	80	90	100	
All Sizes 1 1-1/2 2	6.4 1 Flute	0.25 1 Flute	19	0.75	Cv	0.0385	0.0455	0.0560	0.0719	0.0942	0.124	0.162	0.212	0.278	0.354	0.87
					Kv	0.033	0.039	0.048	0.062	0.081	0.107	0.140	0.183	0.240	0.306	--
					XT	0.778	0.734	0.690	0.653	0.642	0.635	0.637	0.634	0.632	0.656	--
	6.4 3 Flutes	0.25 3 Flutes	19	0.75	Cv	0.0562	0.0725	0.101	0.146	0.216	0.312	0.433	0.588	0.802	1.07	0.90
					Kv	0.049	0.063	0.087	0.126	0.187	0.270	0.375	0.509	0.694	0.926	--
					XT	0.692	0.648	0.639	0.625	0.600	0.586	0.597	0.613	0.620	0.624	--

1.At 100% travel

### M-Flow - Flow Up – CVS Design EZ, Equal Percentage Characteristic

Valve Size, NPS	Port Diameter		Maximum Travel		Angle "A" of Flat	Flow Coefficient	Valve Opening–Percent of Total ravel										FL(1)
	mm	Inches	mm	Inches			10	20	30	40	50	60	70	80	90	100	
All Sizes 1 1-1/2 2	4.8	0.1875	19	0.75	1_55'	Cv	0.015	0.020	0.024	0.028	0.034	0.041	0.048	0.056	0.066	0.075	0.89
						Kv	0.013	0.017	0.021	0.024	0.029	0.035	0.042	0.048	0.057	0.065	--
						XT	0.964	0.888	0.906	0.947	0.942	0.928	0.949	0.947	0.918	0.934	--
					3_25'	Cv	0.016	0.026	0.038	0.052	0.070	0.088	0.107	0.127	0.153	0.181	0.84
						Kv	0.014	0.022	0.033	0.045	0.061	0.076	0.093	0.110	0.132	0.157	--
						XT	0.707	0.697	0.687	0.700	0.675	0.679	0.680	0.680	0.681	0.681	--

1.At 100% travel

**Notes:**

**Notes:**

**Notes:**

CVS Controls Ltd. strives for the highest levels of quality and accuracy. The information included in this publication is presented for informational purposes only. CVS Controls Ltd. reserves the right to modify or change, and improve design, process, and specifications without written notice. Under no circumstance is the information contained to be interpreted to be a guarantee/warranty with regard to our products or services, applicability or use. Selection, use and maintenance are the sole responsibility of the end user and purchaser. CVS Controls assumes no liability for the selection use and maintenance of any product.